

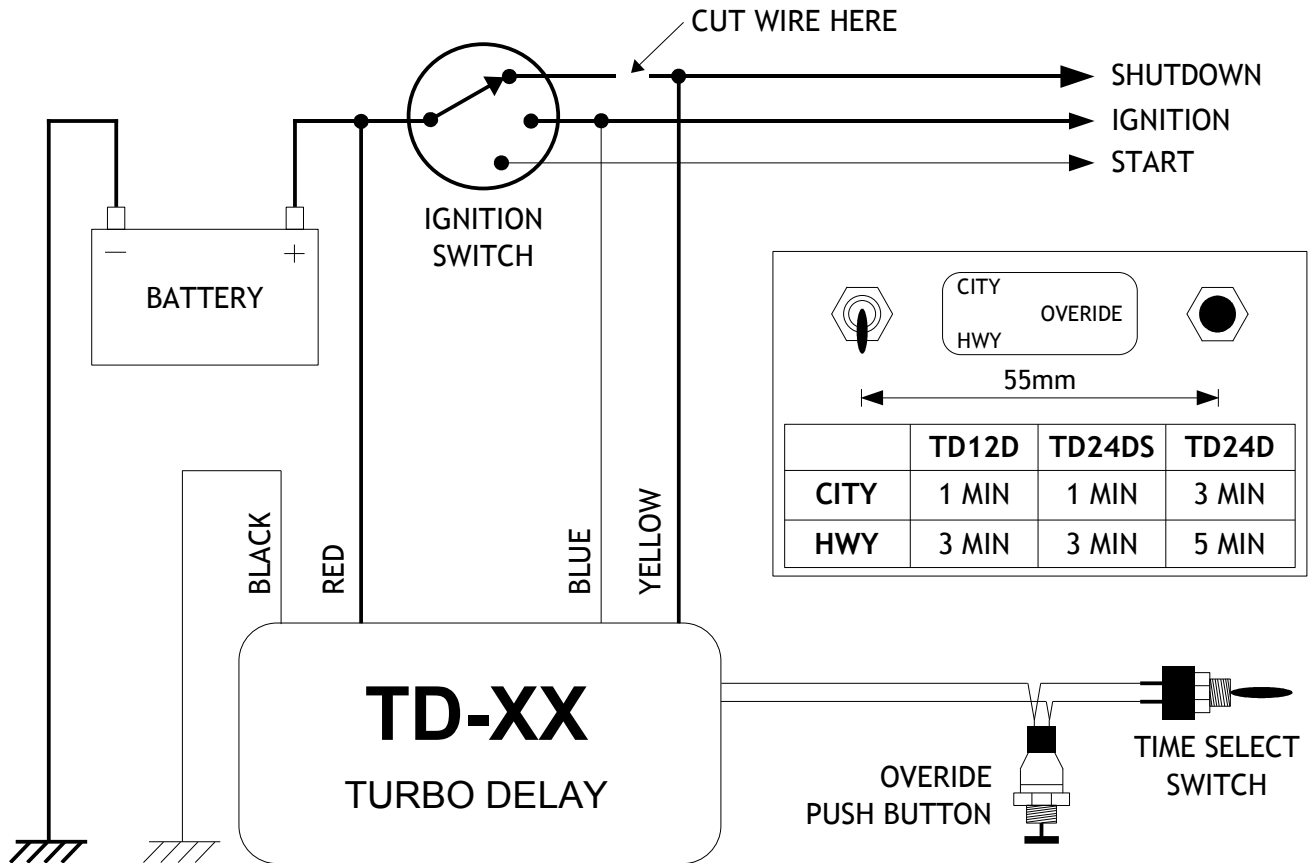

ANYTHING ELECTRONIC (NZ) LTD.

TURBO DELAY

Part No: TD-12D, TD-24D, TD-24DS



INSTRUCTIONS

Cut the ignition wiring and wire in the Turbo Delay as shown. The override and time select switches are mounted on the dash via 7mm holes as shown above. The time select switch is mounted with its unused terminal upwards so that in the CITY position the shorter time is selected. The HWY (highway) position selects the longer time. The two switches are mounted 55mm apart with the decal centered between them.

When the ignition is turned to the OFF position, the Turbo Delay begins its timing procedure. At the end of its time (see table), it will switch a feed to the SHUT DOWN circuit for a period of ~7 seconds, then turn off. During the ~7 seconds the shutdown circuit is activated and turns off the engine. The timer is reset when the ignition is turned on.

Warranty statement on reverse.

ANYTHING ELECTRONIC (NZ) LTD.

7 Bullen Street, PO Box 273, Nelson, New Zealand

Phone : 03 548 5336 - Fax : 03 548 5636

Email : sales@anythingelectronic.co.nz