

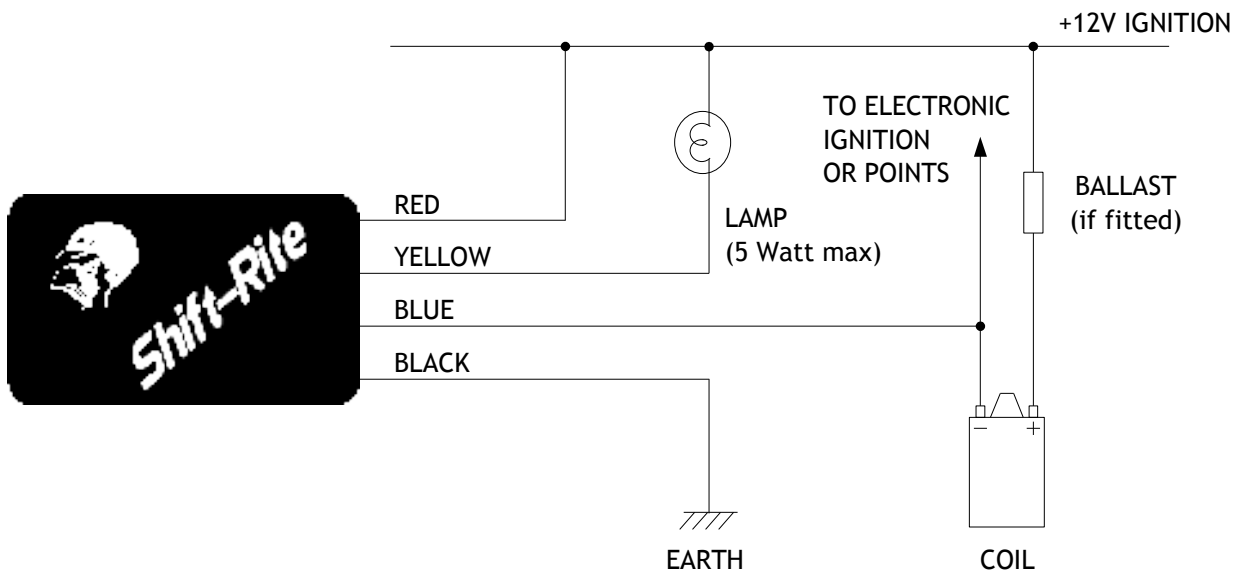

ANYTHING ELECTRONIC (NZ) LTD.

REV-RITE SHIFT LIGHT

Part No: SD404



INSTRUCTIONS

Wire the SD404 to the coil, 12V ignition and earth as shown above. Using a rev counter for reference, run the engine and adjust the setting control on the side of the unit for the correct shift light setting.

Note: We can supply a halogen lamp and mounting bezel. Ask for Part No. SD 502. The maximum lamp wattage is 5W

# CYLINDERS	ADJUSTABLE RPM RANGE
FOUR	4,000 – 16,000
SIX	2,500 – 10,000
EIGHT	2,000 – 8,000

Warranty statement on reverse

ANYTHING ELECTRONIC (NZ) LTD.

7 Bullen Street, PO Box 273, Nelson, New Zealand

Phone : 03 548 5336 - Fax : 03 548 5636

Email : sales@anythingelectronic.co.nz